



PS SERIES PARALLEL RACK SYSTEM START UP GUIDE



Contents

INTRODUCTION	3
WARNING LABELS AND SAFETY INSTRUCTIONS	4
PARALLEL RACK NOMENCLATURE.....	5
GENERAL RACK DESCRIPTION.....	6
TYPICAL REFRIGERATION COMPONENTS.....	6
TYPICAL CONTROL/ POWER COMPONENTS	6
CONTROL THEORY	7
PRE-START UP	7
START UP.....	7
CPC E2E Controller.....	9
STARTUP TROUBLESHOOTING.....	10
REFERENCE DOCUMENTS.....	12

INTRODUCTION

Thank you for purchasing Master-Bilt® refrigeration equipment. This manual contains important instructions for startup, and troubleshooting. Read this entire manual carefully before starting or servicing your Master-Bilt® equipment.



NOTICE

Installation and service of the refrigeration and electrical components must be performed by a refrigeration mechanic or licensed electrician.



DANGER

Equipment MUST be properly grounded. Improper or faulty hook-up of electrical components of the refrigeration units can result in severe injury or death. All electrical wiring hook-ups must be done in accordance with all applicable local, regional or national standards.



NOTICE

Read this manual before installing your refrigeration equipment. Keep the manual and refer to it before doing any service. Failure to do so could result in personal injury or equipment damage.

The portions of this manual covering refrigeration and electrical components contain technical instructions intended only for persons qualified to perform refrigeration and electrical work. This manual cannot cover every installation, use, or service situation. If you need additional information, call or write us:

**Parts and Technical Service Department
Master-Bilt Products
908 Highway 15 North
New Albany, MS 38652
Phone (800) 684-8988
Email: service@master-bilt.com**

WARNING LABELS AND SAFETY INSTRUCTIONS



This is the safety-alert symbol. When you see this symbol, be alert to the potential for personal injury or damage to your equipment.

Be sure you understand all safety messages and always follow recommended precautions and safe operating practices.



NOTICE TO EMPLOYERS

You must make sure that everyone who installs, uses, or services your refrigeration equipment is thoroughly familiar with all safety information and procedures.

Important safety information is presented in this section and throughout the manual. The following signal words are used in the warnings and safety messages:

DANGER: Severe injury or death WILL occur if you ignore the message.

WARNING: Severe injury or death CAN occur if you ignore the message.

CAUTION: Minor injury or damage to your refrigeration can occur if you ignore the message.

NOTICE: This is important installation, operation or service information. If you ignore the message, you may damage your refrigeration.

The warning and safety labels shown throughout this manual are placed on your Master-Bilt® Products refrigeration at the factory. Follow all warning label instructions. If any warning or safety labels become lost or damaged, call your customer service department at (800) 684-8988 for replacements.

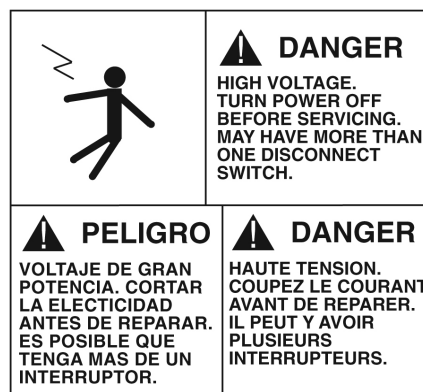

This Label is located on the condensing unit

PARALLEL RACK NOMENCLATURE

PS E A C 5 2 Z C - XXXXX

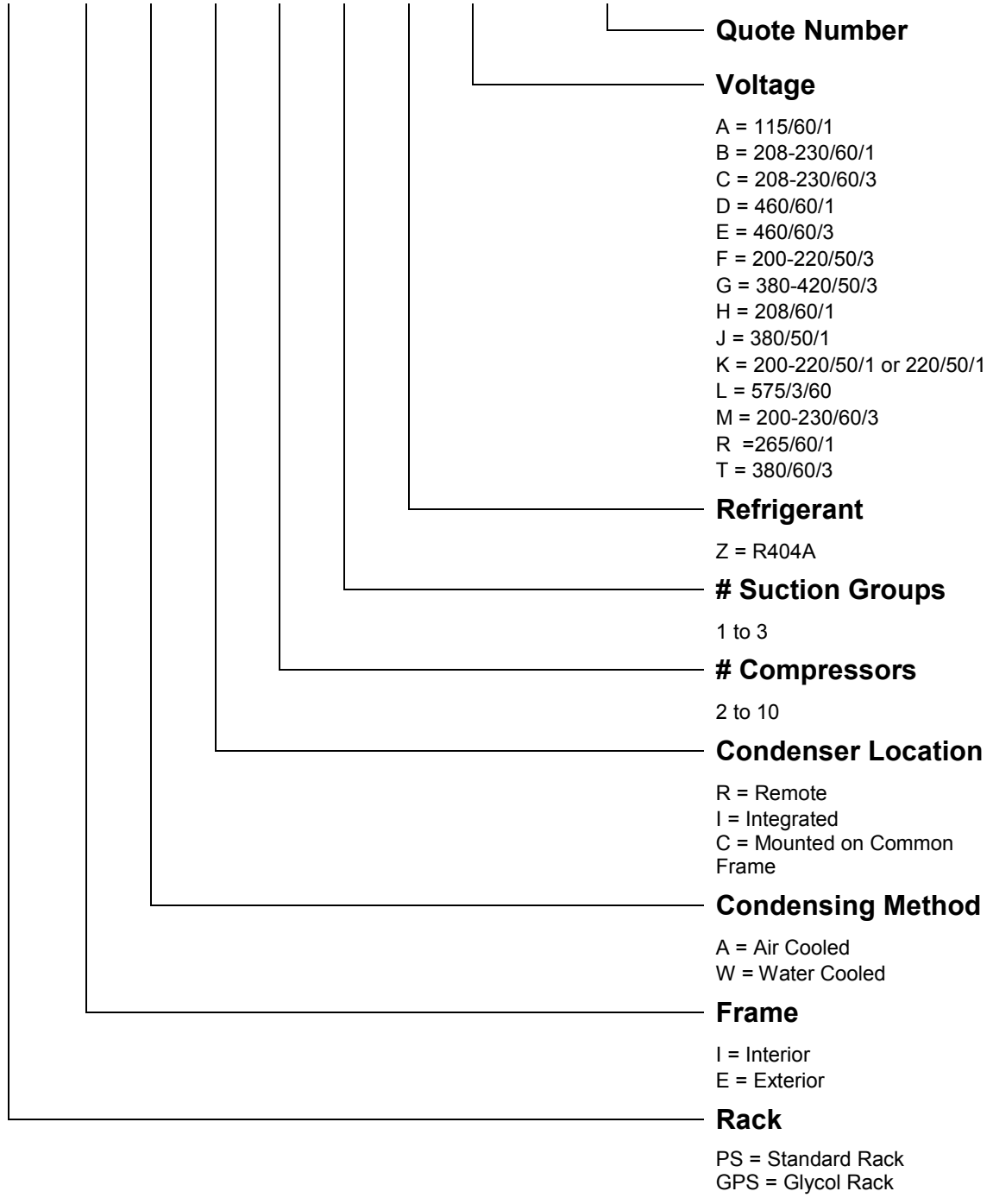

GENERAL RACK DESCRIPTION

Master-Bilt® PS series parallel rack systems operate with up to ten compressors in parallel design. A typical rack system has two separate suction groups and a common discharge and liquid circuit. One suction group is for low temperature equipment with an average temperature of -23°F SST. One suction group is for medium temperature equipment with an average temperature of +23°F SST. Each rack system has one common liquid circuit and one common discharge circuit.

TYPICAL REFRIGERATION COMPONENTS

- 2-10 Scroll or Discus compressors
- Individual Compressor Dual Pressure Controls
- Individual Compressor Oil Level Controls
- Oil Pressure Differential Valve
- Oil Line Sight Glass
- Oil Filter
- Oil Separator
- Air Cooled or Water Cooled Condenser
- Head Pressure and Hot Gas Bypass Valves
- Liquid Receiver with Dual Pressure Relief Valves
- Replaceable Core Liquid Filter/ Drier
- Liquid Sight Glass
- Replaceable Core Suction Filter (one for each group)
- Suction Accumulator (one for each group)

TYPICAL CONTROL/ POWER COMPONENTS

- 220V Control Circuit
- Main Disconnect Switch and Circuit Breaker
- Power Distribution Blocks
- GFCI Service Receptacle (115V)
- CPC E2E RX Rack Controller
- 1 or more CPC Relay Boards
- 1 or more Digital Compressor Controllers (one per suction group)
- Individual Compressor Circuit Breakers
- Individual Compressor Contactors
- Condenser Fan Contactors
- Phase Monitor
- 230V to 24V Transformers for CPC and Oil Controls Power
- Receiver Liquid Level Probe
- Suction, Discharge, and Drop Leg Pressure Transducers
- Suction, Discharge, Drop Leg, and Ambient Temperature Probes
- Walk in Cooler/ Freezer Temperature Probes

CONTROL THEORY

The CPC E2E controller receives pressure and temperature inputs from all devices and controls outputs to maintain set points. SST for a suction group is maintained by reading the pressure input from the suction group and switching or unloading compressors to maintain a programmed pressure set point. Inputs from discharge and drop leg pressure transducers are used to turn on and off fan banks on the condenser. Temperature inputs from walk in coolers are used to open and close solenoids on evaporators to control walk in box temperatures. All set points in the system are changeable in the E2E controller.

PRE-START UP

Pre-charge system with as much refrigerant as the system will take up to the holding capacity of the receiver using the following specifications:

- A vacuum of 500 microns or less must be pulled to properly dehydrate the refrigeration system.
- Use only refrigerant specifically designed for the rack system. This is typically R404A.
- Use high side charging method only.
- System is shipped with initial filter/drier cores installed.
- Ensure adequate oil charge before starting the compressors. Use manufacturer recommended oil type. Add until oil is shown in the upper glass on the oil reservoir.
- Ensure all refrigeration lines are clean and purged.
- Never allow liquid refrigerant to reach the compressors. Damage to the compressors may occur.

START UP

1. Verify all breakers and switches are in the off position.
2. Verify all loads are in refrigeration mode.
3. Turn on condenser power switch and breaker.
4. Turn on all compressor toggle switches.
5. Turn on main power switch and breaker.
6. Turn on control power breaker (2 pole 240V). All compressor contactors should engage while E2E control is booting up. If a contactor did not engage, adjust dual pressure switch and ensure switch is closed.
7. Check the phase monitor to verify that the green light is illuminated. If red, measure input power and adjust voltage on phase monitor. If still red adjust phasing on main power.
8. Review the E2E rack controller.
 - a) Hold Alt and press N. Verify that all relay boards are online.
 - b) Press menu, 7, 1. Verify that all transducers and temperature probes are reading expected values.
 - c) Verify that phase monitor input is an expected value.
 - d) Press Home key to return to main screen.
9. On larger walk in freezers it may be necessary to reduce the temperature slowly to prevent damage to the freezer panels. If this is required follow the steps below.
 - a) Set the initial temperature set point for the freezer at 50°F
 - b) Reduce the temperature set point by 20°F every 24 hours until the required temperature is reached.
10. Turn on breaker for compressor 1 and ensure proper rotation of compressor.
11. Turn on breakers for all other compressors.
12. Monitor suction pressure and discharge pressure for expected operation. Suction pressure decreases with compressor operation and Discharge pressure increases.

13. Compressors will cycle on and off at random while the system is in learning mode. The E2E is building a control algorithm for the compressor control. This is normal and could last up to several hours.
14. Add refrigerant to the high side of the system until the design charge is reached.
 - a) Connect the fill line from a charging set to the liquid line filter port.
 - b) Close the outlet valve on the receiver tank. This will allow liquid to go from the charging tank through the expansion valve and return as vapor to the suction line. The liquid will stack up in the receiver.
 - c) Open and close the receiver outlet valve as required until the receiver has 20% liquid (during coldest condition) with the valve open.
 - d) A vacuum charging core tool can be used to remove the Schrader valve to enable faster charging of refrigerant.

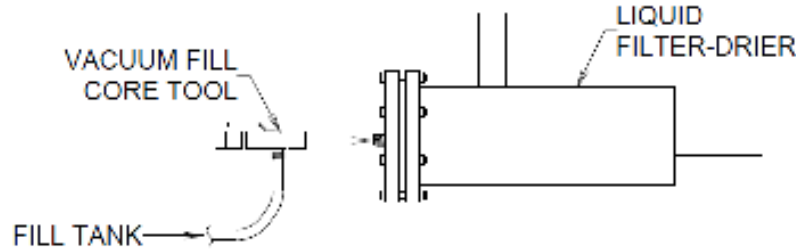

15. Verify the suction header pressure and discharge header pressure with an accurate refrigeration gauge set. Calibrate the E2E as necessary.
16. Set the head pressure valve (typically A8 valve) to achieve 200 psi head pressure.

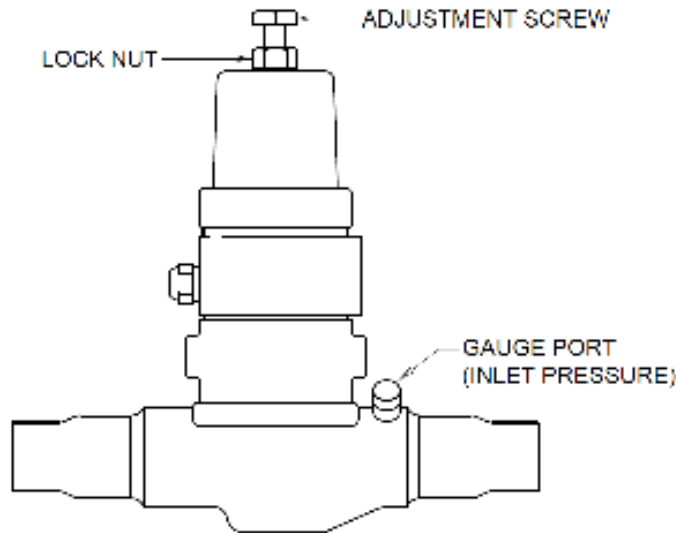

17. Once all coolers are approximately at operating temperature. Set and check expansion valve superheat on each case and cooler.
18. Set each EPR valve where applicable. Adjusting the EPR valve will raise the pressure/ temperature of the evaporator. Suction header pressure must be lower than the EPR setting before performing this step.
19. Verify defrost settings including defrost times and termination temperatures. No more than 25% of the total load should be in defrosting mode at one time.
20. Check oil reservoir after two (2) days of operation and add oil as necessary.
21. After all adjustments have been made, check all valves for proper stem position and replace valve caps.
22. Change filter/ drier cores after start up (approximately 3 days).

CPC E2E Controller

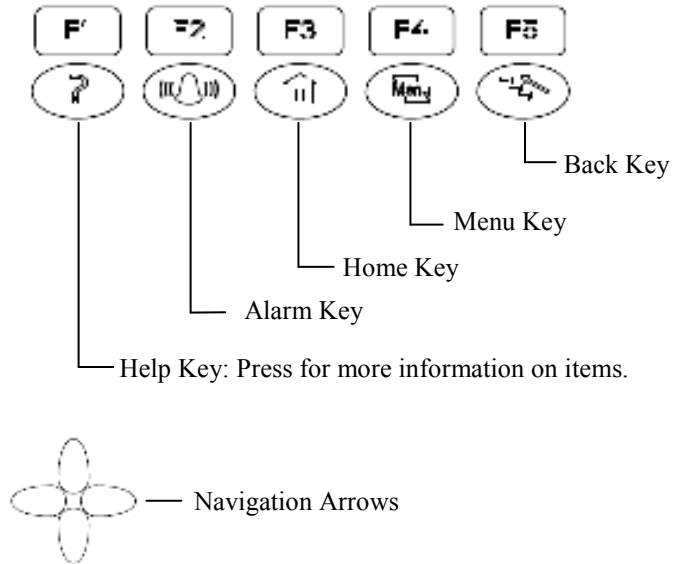
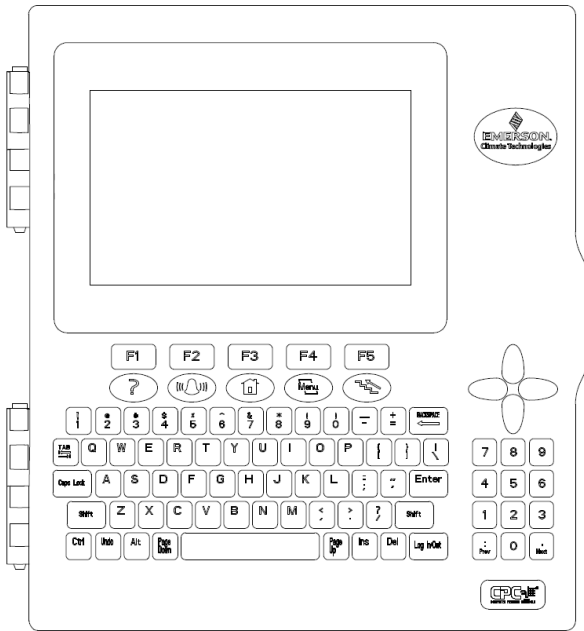

E2 Shortcuts:

All shortcuts below start at home screen (press home key anytime to return home)
 Log In/ Out: Press Log In/Out key. Username: USER, Password: PASS
 Function Key command values are shown on the LCD screen just above the function key.
 Press Help Key at any time to access instructional information.

- Check I/O board status: Menu, 7, 7, 1
- Verify Inputs: Menu, 7, 1
- Verify Outputs: Menu, 7, 2
- Change rack suction pressure set point: Menu, 1, (use arrow to select group), Enter, F5, F2, F2
- Change circuit temperature set point: Menu, 3, (use arrow to select circuit), Enter, F5, F2
- Backup program to USB: Insert USB drive inside cover, Menu, 7, 3, 5, 6, 2, F1
- View alarms: Press Alarm Key
- Clear Alarm: Alarm Key,(select alarm to be cleared), F3, A (for single), B (for all)
- Reset Alarm: Alarm Key,(select alarm to be cleared), F2, A (for single), B (for all)

Notice: Never acknowledge alarms. Always reset or clear.

CPC E2 Quick Reference Card can be found at the end of this manual or in the References Section.

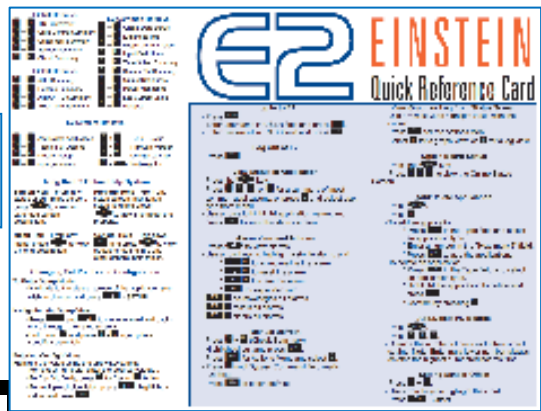

STARTUP TROUBLESHOOTING

Compressor contactors don't engage when E2E calls for compressors:

- Check dual pressure switch on compressor.
 - Initial setting is 25 cut-in, 20 differential, 375 high cut out.
 - Adjust cut-in and differential to operate outside of E2E set points.
- Check voltage at each device along control circuit. See wiring diagram.

Head pressure is too low/ high:

- Adjust A8 head pressure valve until 200 psi is reached.

Evaporator pressure/ temperature too high:

- Fully open EPR valve at evaporators.
- Adjust suction set point downward in small increments until evaporator pressure is reached.
 - See E2 shortcuts above.

Rack failure on phase loss:

- If phase monitor LED is red, adjust voltage range to match input voltage.
- If phase monitor LED is red, verify input phases are aligned to rack.
- If phase monitor LED is green, verify input logic is correct in program.
 - Log into controller with USER, PASS
 - Press: Menu, 7, 1
 - Highlight the input to verify/ change
 - Press: Enter, Enter
 - Screen should be as shown
 - To reverse logic change Active Out to ON, Inactive Out to OFF

Icon on when
Logged in

Hold Ctrl Press N
to turn on Names

Hold Alt Press F
to turn on FULL

The screenshot shows the following interface details:

- Header:** 10-27-15, RX-300 Unit 1, DIGITAL INPUT, NAMES FULL, 16:11:16, *ALARM*
- Main Display:**
 - Board/Point # : 1.6
 - Name : 1-06 PHASE LOS
 - Eng Units : ON-OFF
 - Default Value : OFF
 - Push Button Mode ? : No
 - Active State : OPEN
 - Physical State -
 - Active Out St : OFF
 - Inactive Out St : ON
- Right Panel:**
 - ADVISORY SUMMARY
 - Fails : 9
 - Alarms : 0
 - Notices : 191
 - NETWORK OVERVIEW
 - IONet-1
 - TPA
 - Rev 4.07F01
 - IP 192.168.1.4
 - English-US
- Bottom Menu:**
 - F1: SET ALARMS, F2: SET LOGGING, F5: CANCEL
 - F6: ? (Help), F7: Alarm icon, F8: Home icon, F9: Menu icon, F10: Network icon

- Verify wiring is NO or NC depending on device. Compressors are NC, Solenoids are NC, Defrost Heaters are NO.
- Verify failsafe dip switches are correct. NC relays are UP. NO relays are DOWN.

State of Normally Closed (NC) Contacts on MultiFlex Relay Points				
Fail Safe Switch	Light is ON	Light is OFF	Comm Loss	Power Loss
Up (ON)	Closed	Open	Closed	Closed
Down (OFF)	Open	Closed	Closed	Closed

State of Normally Open (NO) Contacts on MultiFlex Relay Points				
Fail Safe Switch	Light is ON	Light is OFF	Comm Loss	Power Loss
Up (ON)	Open	Closed	Open	Open
Down (OFF)	Closed	Open	Open	Open

I/O boards not online:

- Verify board addressing

Relay Number (Fail Safe Switch)

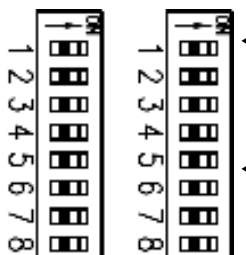
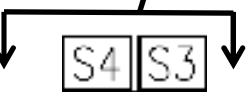
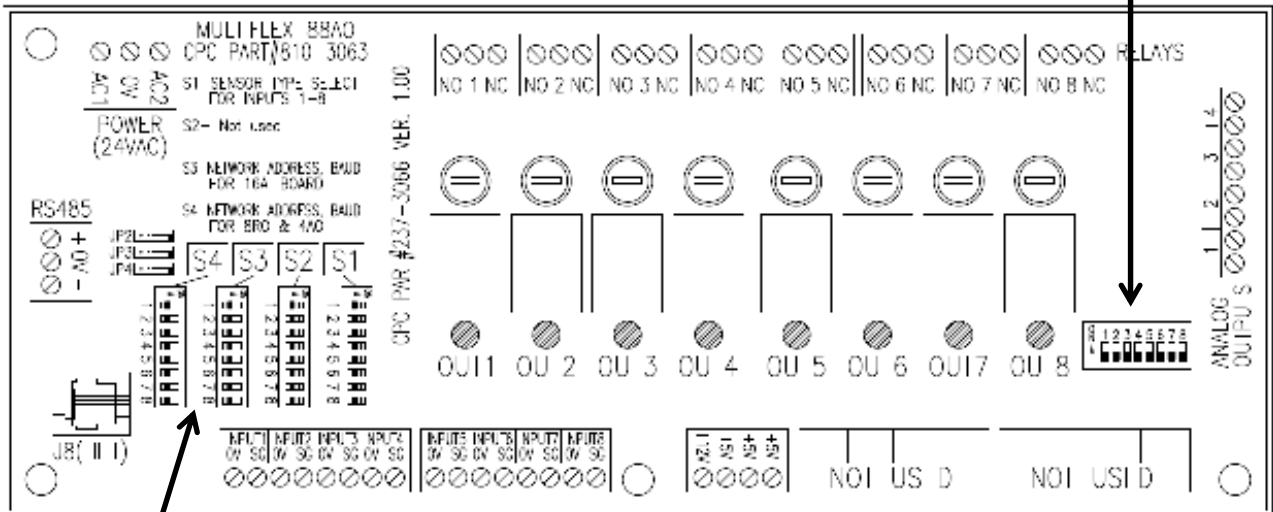
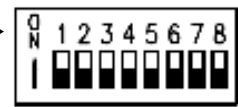

S3 is Input Address 1-5
 S4 is Relay Address 1-5
 Add values from ON dip switches.
 Example: dip 1 and 3 are on. Value of dip 1=1 value of dip 2=0 value of dip 3=4.
 $1+0+4=5$. Network address is 5.

Dip #	1	2	3	4	5
Value On	1	2	4	8	16
Value Off	0	0	0	0	0

E2E locks out compressor on oil failure.

- Verify oil level in oil separator/ reservoir. Oil should be visible in top and bottom sight glass.
- Verify oil level at oil management control (OMB) at compressor. Level in sight glass should be at least half.
- Check LED on OMB control. Green LED= Level OK, Yellow LED=Solenoid open adding oil, Red= Fill time exceeded.
- If oil level is OK, reset or clear alarm in E2E controller.

REFERENCE DOCUMENTS

CPC E2E Operation and Installation Manual, Document 026-1614:

http://www.emersonclimate.com/en-us/Resources/Technical_Documentation/Documents/MNL-0261614-Rev5-E2-IO-Manual.pdf

CPC E2E Quick Reference Card 026-1699:

<http://www.emersonclimate.com/Documents/Retail%20Solutions/0261699.pdf>

CPC MultiFlex I/O Board Installation and Operation Manual, Document 026-1704:

http://www.emersonclimate.com/en-us/Resources/Technical_Documentation/Documents/MNL-0261704-Rev7-MultiFlex-IO-Board-Operation-Manual.pdf

Parker Compact Wide-Range Pressure Regulators, Bulletin 25-94 G

<http://www.parker.com/parker/jsp/documentdisplay.jsp?mgmtid=427d42a204b83110VgnVCM10000048021dacRCRD>

Evaporator Pressure Regulating Valves, Bulletin 90-20, Form SD-73:

<http://www.parker.com/parker/jsp/documentdisplay.jsp?mgmtid=deec166a991b9210VgnVCM10000048021dacRCRD>

<http://www.parker.com/parker/jsp/documentdisplay.jsp?mgmtid=a21d166a991b9210VgnVCM10000048021dacRCRD>

Oil Level Control System, Bulletin 110-10:

<http://www.parker.com/parker/jsp/documentdisplay.jsp?mgmtid=abcf166a991b9210VgnVCM10000048021dacRCRD>