



BLG-48-HGP

BLG-HGP SERIES

Bottom Mounted
 Full-Height
 Swing Glass Door
 Freezer Merchandisers

MODELS

- BLG-23-HGP
- BLG-27-HGP
- BLG-48-HGP
- BLG-74-HGP

FEATURES

Glass Door Features:

- Most energy efficient freezer door in the industry – zero heat
- Anti-fog coating means doors are always clear, even during openings and heavy use
- Increased reliability by eliminating electrical components

- 1³/₄" thick state-of-the-art, foamed-in-place "zero ODP" polyurethane insulation provides high R-value
- Four adjustable heavy-duty epoxy-coated cantilever shelves with price tag molding per door
- Merchandiser profile matches other BLG/BMG Plus refrigerator and freezer models

- Refrigerant controlled by capillary tube
- Temperature range: 5° to -15°F (-18° to -26°C)

WARRANTY

- **Standard limited three year parts and labor**
- **Additional two year coverage on compressor part**

CONSTRUCTION

- Standard interior double row LED lighting
- Standard programmable electronic controller featuring:
 - Audible and visual alarm
 - Eliminates room thermostat, defrost termination/fan delay control, defrost timer and digital thermometer or other temperature indicator
- 24 gauge painted textured galvanized steel interior and exterior
- Standard finishes: White interior/white exterior or black exterior/black interior
- Stainless steel floor
- Adjustable legs for leveling

DOORS

- Full-height doors
- Auto-close, triple pane
- 90° hold-open feature
- Contemporary style door frame and handles
- Heavy-duty universal workflow handles
- Easily replaceable snap-in magnetic vinyl door gaskets

REFRIGERATION

- Self-contained bottom mount refrigeration system designed for optimum energy efficiency and low noise
- Top mounted, low profile interior evaporator housing
- Energy-free condensate removal
- Refrigerant: R290

OPTIONS

- Add suffix "R" for remote refrigeration (BLG-48-HGP & BLG-74-HGP models only)
- Stainless steel interior and/or exterior
- Custom exterior colors
- Additional shelving
- Flat bottom shelf with legs
- Bottom baskets
- Casters
- Leg kits
- Door locks
- Proximity switches



BLG-HGP SERIES

BOTTOM MOUNTED FULL-HEIGHT SWING GLASS DOOR FREEZER MERCHANDISERS

TECHNICAL SPECIFICATIONS

MODEL	DIMENSIONS (in.)			DIMENSIONS (mm)			VOLTS	AMPS	UNIT H.P.	NO. OF DOORS	NO. OF SHELVES	SHELF SIZE (in.)	WEIGHT CAP. PER SHELF (LB/KG)	CAP. CU. FT.	SHIP WT. (LB/KG)
	L	D*	H	L	D*	H									
BLG-23-HGP	27	32 ¹ / ₄	79	686	819	2007	115	5.4	3/4	1	4	22 ¹ / ₂ L x 21 ¹ / ₂ D	92/42	22.1	365/166
BLG-27-HGP	30	32 ¹ / ₄	79	762	819	2007	115	5.4	3/4	1	4	25 ¹ / ₂ L x 21 ¹ / ₂ D	105/48	25.0	380/173
BLG-48-HGP	52	32 ¹ / ₄	79	1321	819	2007	115	11.0	1	2	8	23 ¹ / ₂ L x 21 ¹ / ₂ D	92/42	45.7	575/261
BLG-74-HGP	78	32 ¹ / ₄	79	1981	819	2007	115	12.7	**	3	12	23 ¹ / ₂ L x 21 ¹ / ₂ D (ends), 25 ¹ / ₂ L x 21 ¹ / ₂ D (center)	92/42 (ends), 105/48 (center)	70.2	770/350

*Includes door handle and rear drainline cover. **Contains two 115/60/1 3/4 HP condensing units.

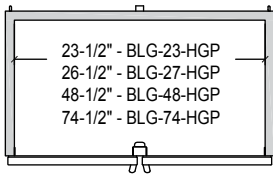

PLAN VIEW

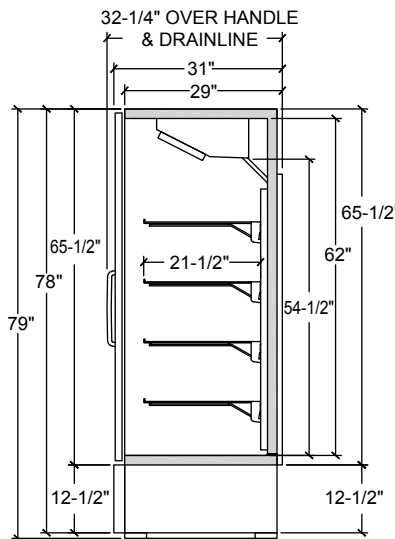

SIDE VIEW

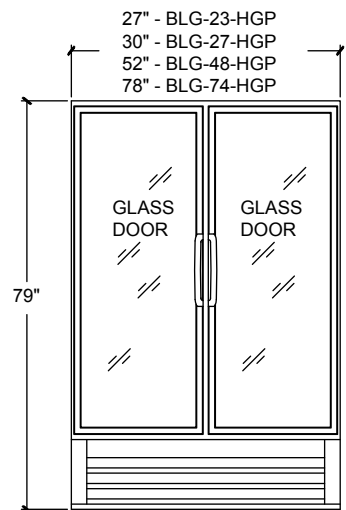

ELEVATION VIEW

LISTINGS



- Listed under NSF-7 for the storage and/or display of packaged food
- Meets Canadian energy efficiency regulations

HOOKUP

All models via plug in, 10 foot long, flexible three wire 14/3 cord with molded plug.

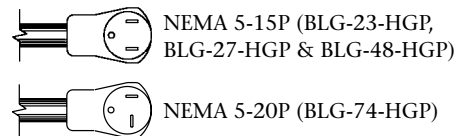

BID SPECIFICATIONS

Item no. BLG-____-HGP. Provide ____ Bottom Mounted Full-Height Swing Glass Door Freezer Merchandiser(s), Master-Bilt® model no. BLG-____-HGP.

Merchandiser will be constructed of 24 gauge painted textured galvanized steel interior and exterior. Standard equipment will include interior LED lighting, programmable electronic controller system, and four

epoxy-coated cantilever shelves with price tag molding per door.

Full-height, auto-close doors will be equipped with triple pane glass and anti-fog coating on inside.

Refrigeration system will be self-contained and designed for optimum energy efficiency and low noise. An energy-free condensate removal system will also be standard.

The refrigerant will be R290. Temperature range will be 5° to -15°F (-18° to -26°C).

Merchandiser to have standard limited 3 year parts and labor warranty with additional 2 year coverage on compressor part.

Merchandiser to be UL and C-UL listed and UL EPH classified. Merchandiser will also meet Canadian energy efficiency regulations.

NOTE: Cabinet designed for optimum performance in air-conditioned area at 75°F ambient and 55% relative humidity. All specifications subject to change without notice.



908 Highway 15 North • New Albany, MS 38652
PHONE: 800-647-1284 or 662-534-9061 • FAX: 800-232-3966 or 662-534-6049 • www.master-bilt.com