



BMG-48-SLP

BMG-SLP SERIES

Bottom Mounted
 Full-Height
 Slide Glass Door
 Refrigerator Merchandisers

MODELS

- BMG-48-SLP
- BMG-74-SLP

FEATURES

CONSTRUCTION

- Standard interior overhead LED lighting
- Electronic digital thermostat
- 24 gauge painted textured galvanized steel interior and exterior
- Standard finishes:
 White interior/white exterior or black exterior/black interior
- Stainless steel floor
- 1³/₄" thick state-of-the-art, foamed-in-place "zero ODP" polyurethane insulation provides high R-value
- Adjustable legs for leveling
- Four adjustable heavy-duty epoxy-coated cantilever shelves with price tag molding per door
- Merchandiser profile matches other BLG/BMG Plus refrigerator and freezer models

DOORS

- Full-height doors
- Auto-close, double pane, safety glass doors
- Contemporary style door frame

REFRIGERATION

- Self-contained bottom mount refrigeration system designed for optimum energy efficiency and low noise
- Top mounted, low profile interior evaporator housing
- Energy-free condensate removal
- Refrigerant: R290
- Temperature range: 34° to 41°F (1° to 5°C)

WARRANTY

- **Standard limited three year parts and labor**
- **Additional two year coverage on compressor part**

OPTIONS

- Stainless steel interior and/or exterior
- Custom exterior colors
- Additional shelving
- Flat bottom shelf with legs
- Bottom baskets
- Casters
- Leg kits
- Proximity switches



BMG-SLP SERIES

BOTTOM MOUNTED FULL-HEIGHT SLIDE GLASS DOOR REFRIGERATOR MERCHANDISERS

TECHNICAL SPECIFICATIONS

MODEL	DIMENSIONS (in.)			DIMENSIONS (mm)			VOLTS	AMPS	UNIT H.P.	NO. OF DOORS	NO. OF SHELVES	SHELF SIZE (in.)	WEIGHT CAP. PER SHELF (LB/KG)	CAP. CU. FT.	SHIP WT. (LB/KG)
	L	D*	H	L	D*	H									
BMG-48-SLP	52	31	79	1321	787	2007	115	6.8	1/3	2	8	23 ¹ / ₂ L x 21 ¹ / ₂ D	92/42	45.7	530/241
BMG-74-SLP	78	31	79	1981	787	2007	115	7.0	1/2	3	12	23 ¹ / ₂ L x 21 ¹ / ₂ D (ends), 25 ¹ / ₂ L x 21 ¹ / ₂ D (center)	92/42 (ends), 105/48 (center)	70.2	715/325

*Includes rear drainline cover.

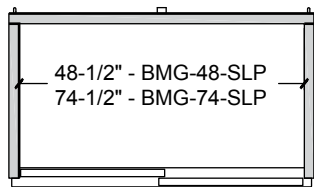

PLAN VIEW

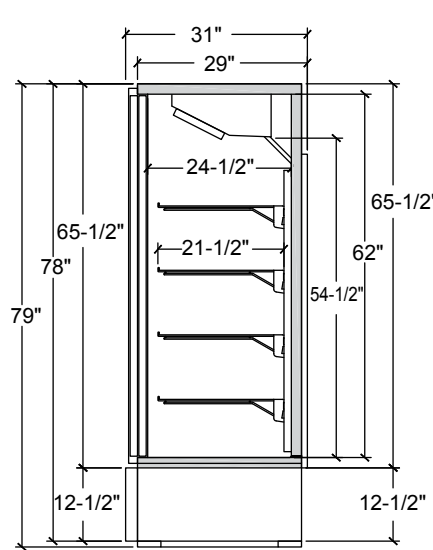

SIDE VIEW

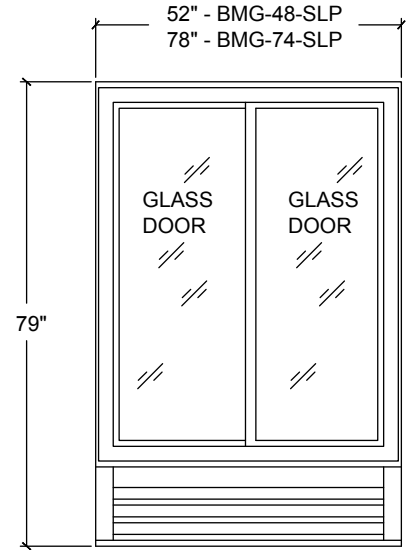

ELEVATION VIEW

LISTINGS



- Listed under NSF-7 for the storage and/or display of packaged food
- Meets Canadian energy efficiency regulations

HOOKUP

All models via plug in, 10 foot long, flexible three wire 14/3 cord with molded plug.

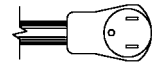

NEMA 5-15P

BID SPECIFICATIONS

Item no. BMG-____-SLP. Provide ____ Bottom Mounted Full-Height Slide Glass Door Refrigerator Merchandiser(s), Master-Bilt® model no. BMG-____-SLP. Merchandiser will be constructed of 24 ga. painted textured galvanized steel interior and exterior. Standard equipment includes interior overhead LED lighting and four epoxy-coated cantilever shelves with price

tag molding per door. Full-height, auto-close doors will be equipped with double pane safety glass. Refrigeration system will be self-contained and designed for optimum energy efficiency and low noise. An energy-free condensate removal system will also be standard. The refrigerant will be R290. Temperature range will be 34° to 41°F (1° to 5°C).

Merchandiser to have standard limited three year parts and labor warranty with additional two year coverage on compressor part. Merchandiser to be UL and C-UL listed and UL EPH classified. Merchandiser will also meet Canadian energy efficiency regulations.

NOTE: Cabinet designed for optimum performance in air-conditioned area at 75°F ambient and 55% relative humidity. All specifications subject to change without notice.



908 Highway 15 North • New Albany, MS 38652
PHONE: 800-647-1284 or 662-534-9061 • FAX: 800-232-3966 or 662-534-6049 • www.master-bilt.com