BOTTLE COOLERS

Installation, Operation and Maintenance Instructions

INSPECTION

When the equipment is received, all items should be carefully checked against the Bill of Lading to ensure all crates and cartons have been received. Do not sign the freight bill clear until the freight has been properly inspected for damage. All units should be inspected for damage including concealed damage by uncrating immediately. If any damage is found, it should be reported to the carrier at once, noted on the Bill of Lading and a claim should be filed with the carrier. This equipment has been inspected and tested in the manufacturing facility and has been crated in accordance with transportation rules and guidelines. The manufacturer is not responsible for freight loss or damages.

INSTALLATION

CAUTION: This unit uses a flammable refrigerant. Use care when handling and operating to avoid damaging the refrigerant tubing or increasing the risk of a leak.

After removing the unit from the packaging, clean the interior and exterior surfaces of the unit with soap and water and a rinse with clean water. Do not use chlorinated cleaners on the surfaces as they can cause corrosion.

This unit is designed for indoor use only. Be sure to locate the unit where the floor can support the weight of the unit and product installed inside of it. The refrigeration system located at the bottom right of the unit requires free air access for proper operation. Allow a minimum of seven (7) inches between the back of the cabinet and the wall. Do not locate the unit next to heat generating equipment or in direct sunlight.

Confirm that the proposed electrical outlet has the correct voltage, frequency and current carrying capacity for the requirements of the unit. This information is noted on the data plate on the inside left wall of the unit. The unit should be isolated on a circuit. Do not use an extension cord to get power to the unit. Improper electrical installations will void the compressor warranty. To prevent shock and fire, be sure the unit is properly grounded.

Local health codes may require that the unit be sealed to the floor with an NSF approved silicone sealant if it is not on legs or casters. After the unit is set in its desired location, simply apply a bead of sealant around the base of the unit and smooth it out.

The product dividers are packaged inside the unit. The product dividers are shipped installed. They can be relocated to your desired position by using the extra bushings located inside the cabinet. The dividers are spring loaded. Push the divider towards the back of the cabinet to release it from the front bushings then swing the front to one side and remove from the rear bushings. Reverse this procedure to re-install in a new location.

The cap catcher is also shipped inside the cabinet. The cap catcher is to be installed on the right front of the cabinet using the two mounting screws on the cabinet and the two keyhole slots on the back of the cap catcher. Loosen the screws and slide the cap catcher over them. Leave the screws loose so the cap catcher can be removed for emptying.

OPERATION AND MAINTENANCE

All service should be performed by factory authorized personnel. All component parts will be replaced with like components to minimize the risk of possible ignition due to incorrect parts or improper service.

This cooler is designed to maintain your product temperature within the most desirable range of +34°F to +38°F. You can expect this temperature with the proper temperature control setting and in a normal environment. It is important to remember that when the product is delivered, it must be placed inside the cooler as soon as possible to avoid excessive warm up. If this happens, it may take many hours for the temperature to be reduced to the desirable range.

The temperature controller is located on the inside back wall of the unit. Turn the control clockwise for cooler temperatures and counterclockwise for warmer temperatures. Allow the unit several hours to respond to temperature control adjustments.

When loading the cabinet with product, do not block the air flow path at the back. Blocking the air flow may decrease performance. Maintain clearance between the contents and air duct for best performance.

This equipment is intended for the storage and display of non-potentially hazardous bottled or canned products only.

Cleaning

Beginning with the initial installation, the interior surfaces of the cabinet should be periodically cleaned with a solution of warm water and baking soda. This solution will remove any odors from spillage that has occurred. The exterior of the cabinet should also be cleaned frequently with a commercial stainless steel cleaner, glass cleaner or mild soap solution. Do not use chlorinated cleaners on any surfaces.

Note: do not use stainless steel cleaners or other solvent-based chemicals on the plastic parts (door handle or trim strips) as they can cause failure. Use mild soap and warm water on plastic parts.

The product dividers can be cleaned in a sink with a mild soap solution and a soft bristled brush.

Periodically the unit should be emptied and cleaned out. There is a drain in the floor of the cabinet that drains to a drain hose on the back of the cabinet in the compressor compartment. Be sure to use this drain line for cleaning out the cabinet interior.

Condenser Coil

Prior to cleaning the condenser coil disconnect the unit from power. Periodic cleaning of the condenser coil will aid the heat transfer of the refrigeration system and increase its efficiency. To accomplish this, remove the lower front grill from the cabinet. The condenser coil is located behind the grill. Use a soft bristled brush to remove any dirt particles that are on the fins of the condenser coil. Use a vacuum cleaner or compressed air to remove the loosened particles. Replace the front grill and reconnect the unit to power. Failure to clean the condenser coil can lead to performance loss and compressor failure.

TROUBLESHOOTING

Problem	Remedy
Compressor will not start	<ul style="list-style-type: none"> • Check the power cord and make sure it is plugged in and has power. • Check the temperature controller. If it is in the “OFF” position, turn it clockwise to set a desired temperature.
Poor performance	<ul style="list-style-type: none"> • Move the unit from direct sunlight. • Move the unit away from heating devices. • Install the unit in a well ventilated place, with at least 2 inches of clearance on all sides. • Clean the condenser if heavy dust is collected. • Clear contents from blocking the inside air duct. • Check the temperature controller for correct setting. • Check the covers and be sure they are completely closed.
Unit noisy	<ul style="list-style-type: none"> • Install the unit on a level solid surface. • Maintain 2 inches of clearance from the wall. • Check for loose parts or mounting. • Keep the tubing free from any contact to avoid rattle.
Condensation on cabinet exterior and/or floor	<ul style="list-style-type: none"> • Reduce humidity where the unit is installed. • Check the drain line to make sure it is not disconnected inside the cabinet and it drains into the drain pan in the compressor area.

SPECIFICATIONS

Model	# Dividers	Electrical	Amps	NEMA Plug	HP	12 oz. Can Capacity	Refrigerant
BC50	3	115/60/1	3.5	5-15P	3/8	857	R290
BC65	4	115/60/1	3.5	5-15P	3/8	1191	R290
BC80	5	115/60/1	3.5	5-15P	3/8	1575	R290
BC95	6	115/60/1	3.5	5-15P	3/8	1893	R290

Above specifications are subject to change without prior notice for quality improvement.

BC SERIES PARTS LIST

ITEM NO.	PART NAME and DESCRIPTION	BC50	BC65	BC80	BC95	PART NO.
6	DOOR RAIL LEFT	X	X	X	X	157656
	DOOR RAIL FRONT	X				157658
7	DOOR RAIL FRONT		X			157659
	DOOR RAIL FRONT			X		157660
	DOOR RAIL FRONT				X	157661
8	DOOR RAIL BRACKET LEFT OR RIGHT	2	2	2	2	157662
9	AIR GUIDE BRACKET	2	2	2	2	157663
10	DOOR RAIL BRACKET FRONT	X				157665
	DOOR RAIL BRACKET FRONT		X			157666
	DOOR RAIL BRACKET FRONT			X		157667
	DOOR RAIL BRACKET FRONT				X	157668
11	DOOR RAIL RIGHT	X	X	X	X	157669
12	DUCT BRACKET	2	X	X	X	157670
13	DUCT GUIDE LEFT	X	X	X	X	157671
	DUCT GUIDE RIGHT	X	X	X	X	157672
14	EVAP FAN MOTOR	2	2	3	3	145709
	EVAP FAN BLADE	2	2	3	3	145710
15	EVAP COIL ASSY (R134a units)	X	X			149824
	EVAP COIL ASSY (R290 units)	X	X			161790
	EVAP COIL ASSY (R134a units)			X	X	157678
	EVAP COIL ASSY (R290 units)			X	X	161799
16	DRAIN GUIDE	X	X			157682
	DRAIN GUIDE			X	X	157683
17	EVAP DRAIN ELBOW A	X	X	X	X	157684
18	EVAP DRAIN ELBOW B	X	X	X	X	157685
19	UNIT COOLER DUCT 50	X				157687
	UNIT COOLER DUCT 65		X			157688
	UNIT COOLER DUCT 80 (R134a UNITS)			X		157689
	UNIT COOLER DUCT 80 (R290 UNITS)			X		161800
	UNIT COOLER DUCT 95 (R134a UNITS)				X	157690
	UNIT COOLER DUCT 95 (R290 UNITS)				X	161801
20	EVAP FAN COVER	X	X			157694
	EVAP FAN COVER (R134A UNITS)			X	X	157695
	EVAP FAN COVER (R290 UNITS)			X	X	161802
21	SHELF/DIVIDER BUSHINGS	42	57	90	102	157696
22	SHELF/DIVIDER SPRING	3	4	5	6	157697
23	SHELF/DIVIDER	3	4	5	6	157698
24	THERMOSTAT CONTROL ASSY (R134a UNITS)	X	X	X	X	157703
	THERMOSTAT CONTROL ASSY (R290 UNITS)	X	X	X	X	161803
28	OPENER COVER ASSY	X	X	X	X	159158
30	CAPILLARY TUBE (R134a UNITS)	X	X	X	X	159160
	HEAT EXCHANGER (CAP TUBE/SUCTION LINE) (R290 UNITS)	X	X	X	X	161805
34	COMPRESSOR SK1A1C-L2W (R134a UNITS)	X	X	X	X	150311
	COMPRESSOR (R290 UNITS)	X	X	X	X	161767
	COMPRESSOR ELECTRONIC KIT (R134a UNITS)	X	X	X	X	150312
	COMPRESSOR ELECTRONIC KIT (R290 UNITS)	X	X	X	X	161768
37	DRYER (R134a UNITS)	X	X	X	X	159166
	DRYER (R290 UNITS)	X	X	X	X	161786
38	CONDENSER 50, 65, 80, 95	X	X	X	X	159170
39	CONDENSER FAN MOTOR	X	X	X	X	145751
	CONDENSER FAN MOTOR BLADE	X	X	X	X	145749
40	CABINET BASE	X	X	X	X	159178
41	FRONT GRILL	X	X	X	X	159180
47	EVA CENTER GUIDE	X	X	2	2	159182
50	DOOR 50	2				159190
	DOOR 65 & 95		2		3	159192
	DOOR 80			3		159194
51	SIDE COVER	X	X	X	X	159199
52	TOP BRACKET 1			2	2	159201
	TOP BRACKET 2	2	2			159202
53	DOOR LOCK KEY	2	2	3	3	160743
56	FAN CONTROL PCB KIT	X	X	X	X	161579
	CASTERS (4) 2 LOCKING & 2 NON-LOCKING PLATE TYPE	X				160620
	CASTERS (6) 3 LOCKING & 3 NON-LOCKING PLATE TYPE		X	X	X	160621
	DOOR LOCK W/KEY	X	X	X	X	161560

EXPLODED VIEW PARTS LIST – BC50 & BC65

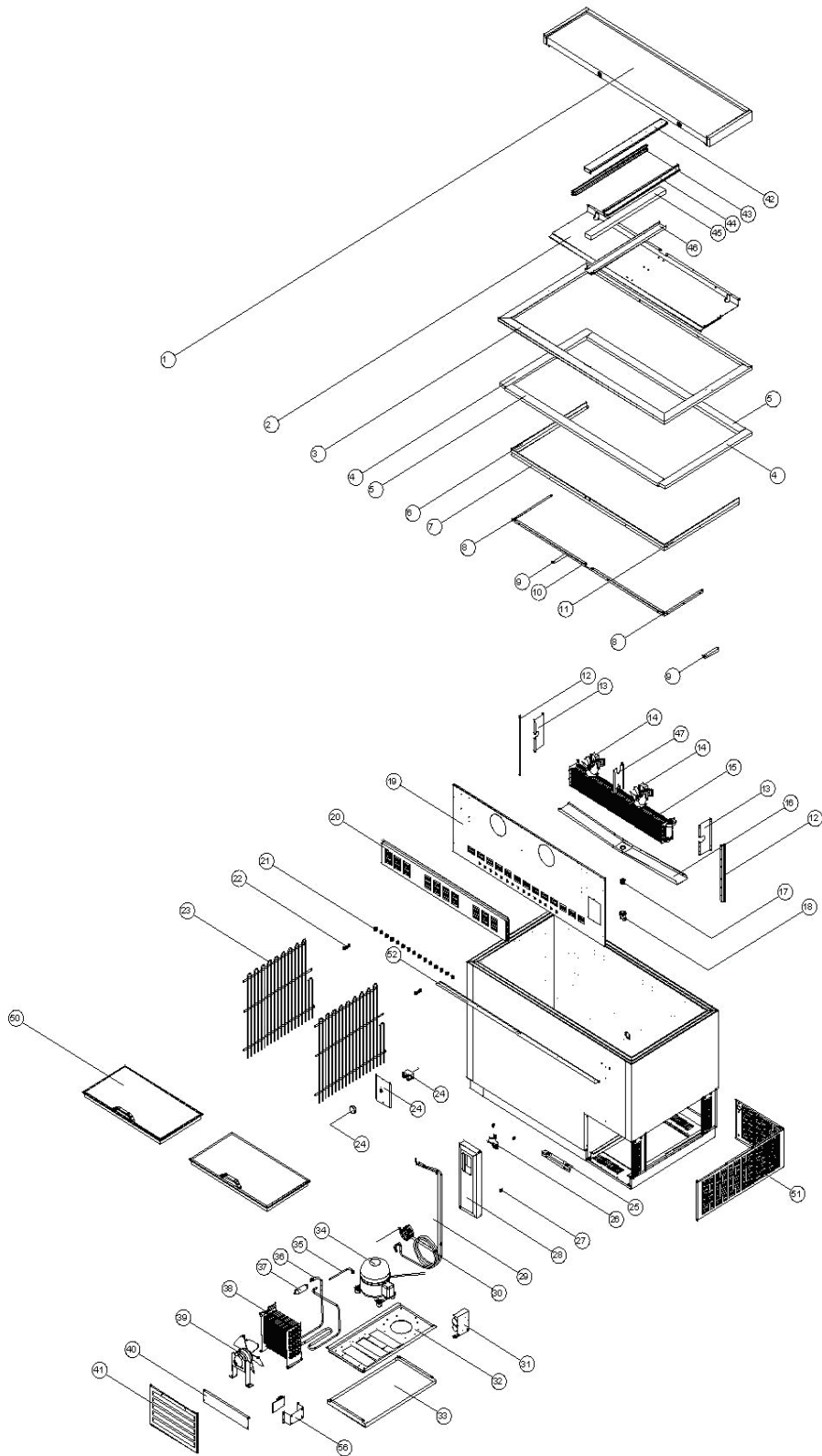

EXPLODED VIEW PARTS LIST - BC80 & BC95

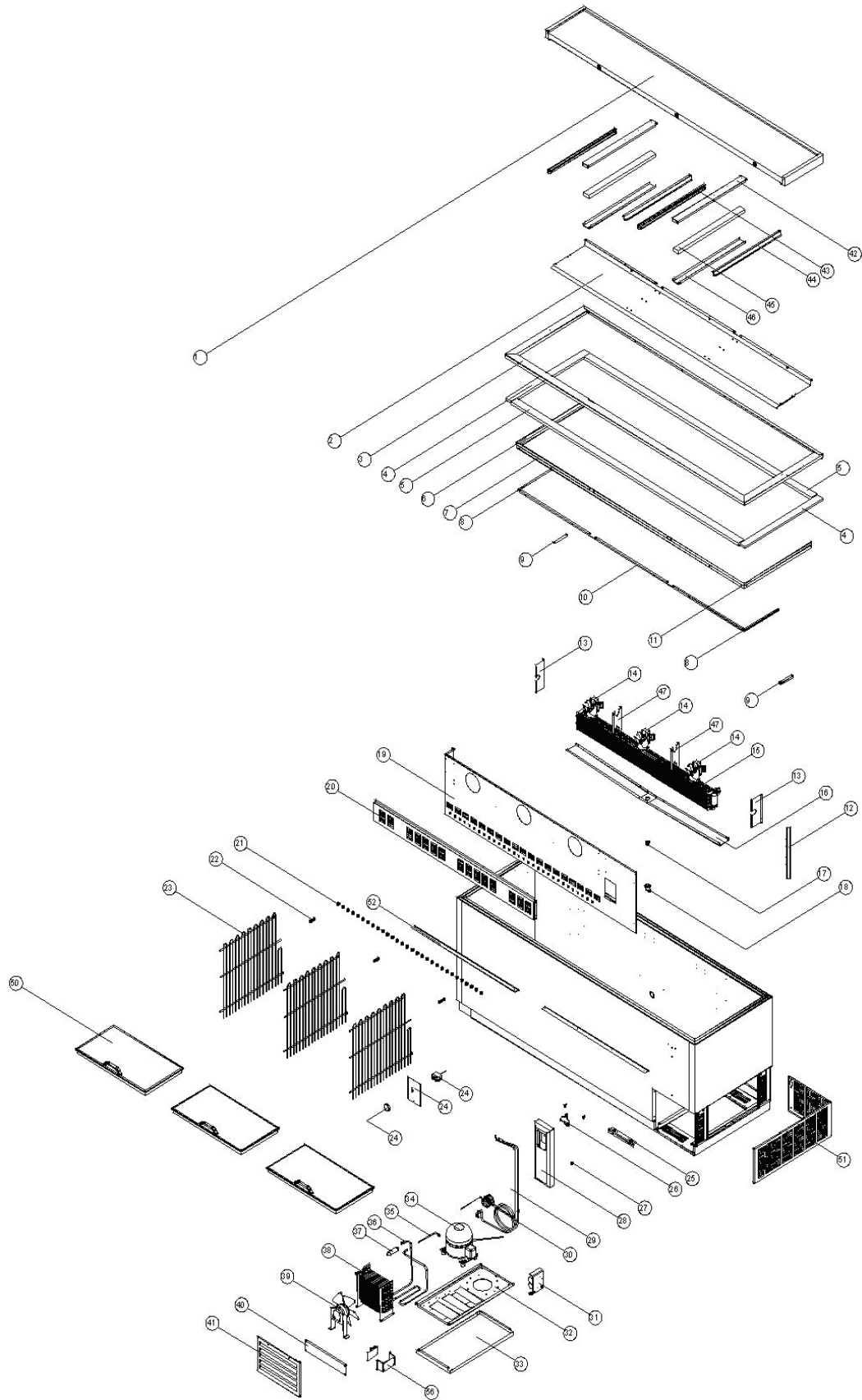

WIRING DIAGRAM

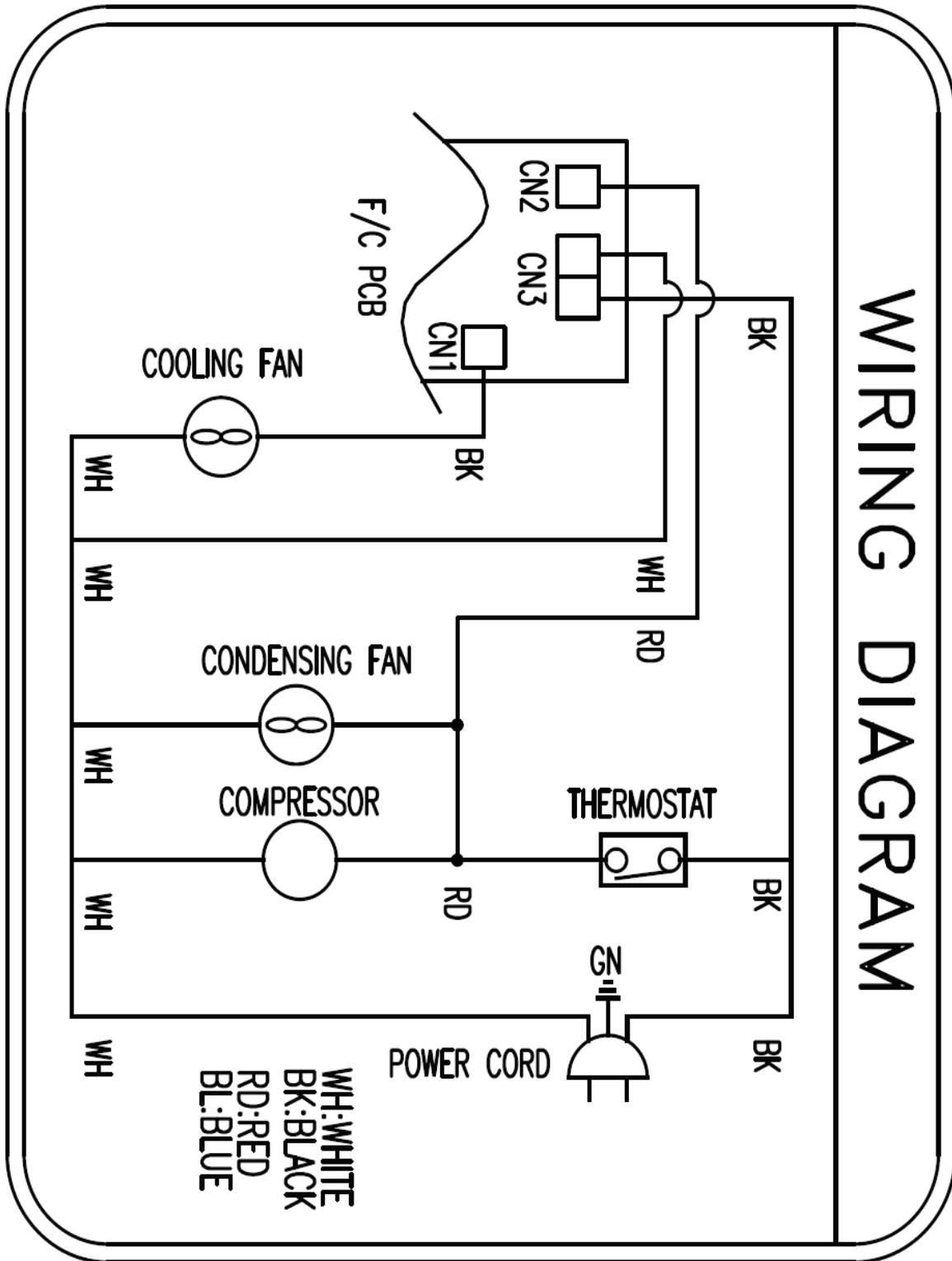

WIRING DIAGRAM