

ITEM NO. _____
 PROJECT _____
 LOCATION _____
 DATE _____ QTY. _____

FUSION™ MBCTM7-B SERIES

Countertop Refrigerator Merchandiser

MODEL
 MBCTM7-B



MBCTM7-B



FEATURES

CONSTRUCTION

- Standard LED lighting
- Black painted steel exterior
- White painted interior
- Foamed-in-place with low ODP polyurethane insulation
- Two adjustable shelves
- Four adjustable levelers

DOORS

- Right hinged with pivot hinges
- Magnetic gaskets
- Durable pull handle

REFRIGERATION

- Self-contained refrigeration system
- Refrigerant: R290
- Operating temperature: 38°F (3°C)

WARRANTY

- Standard limited one year parts and labor
- Additional four year coverage on compressor part

OPTIONS

- Extra shelf
- Locking kit (field installed)

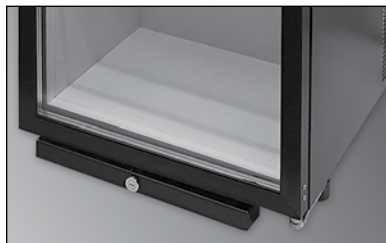

TECHNICAL SPECIFICATIONS

Models	MBCTM7-B
Crated Weight (lbs) (kg)	128 (58)
Crated Height (in) (mm)	42 (1067)
Crated Width (in) (mm)	27 (686)
Crated Depth (in) (mm)	22 (559)
Interior Height (in) (mm)	34-1/4 (870)
Interior Width (in) (mm)	18-1/2 (470)
Interior Depth (in) (mm)*	20-11/16 (525)
Overall Height (in) (mm)**	38 (965)
Overall Width (in) (mm)	21-1/4 (540)
Overall Depth (in) (mm)	25-3/4 (654)
Gross Cubage (CuFt) (L)	7.0 (198)
Number of Shelves	2
Condensing Unit Size	1/5 HP
Refrigerant	R290
Electrical Characteristics	115/60/1
Cord and Plug Furnished	Yes
NEMA Plug Configuration	5-15P
Total Amp Draw	3.1
Capacity (12 oz. cans/12 oz. bottles)	248/128

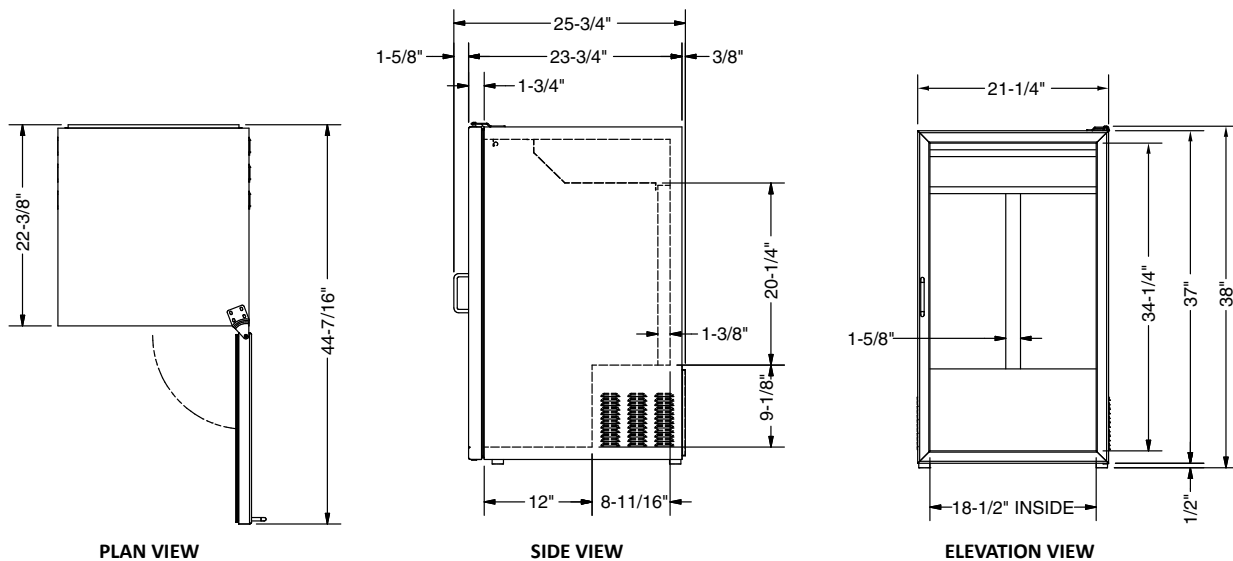

LISTINGS



HOOKUP

Via plug in, flexible three wire 14/3 cord with molded plug.

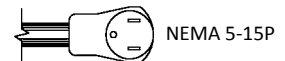

BID SPECIFICATIONS

Item no. MBCTM7-B.
Provide _____ Countertop Merchandiser(s), Master-Bilt® model no. MBCTM7-B.
Merchandiser standard finish will be black painted exterior and white painted interior.
Merchandiser will be equipped with standard

LED lighting and two adjustable shelves. The non-reversible door will feature magnetic gasket, pivot hinges and a pull handle.
The refrigeration system will be self-contained and will use R290 refrigerant. The operating temperature will be 38°F (3°C).

Merchandiser to have standard limited one year parts and labor warranty with additional four year coverage on compressor part.
Merchandiser to be UL listed in the U.S. and Canada and ETL Sanitation listed.

NOTE: Cabinet designed for optimum performance in air-conditioned area at 75°F ambient and 55% relative humidity. All specifications within this publication subject to change without notice.